

KÖCO K 800 - data sheet

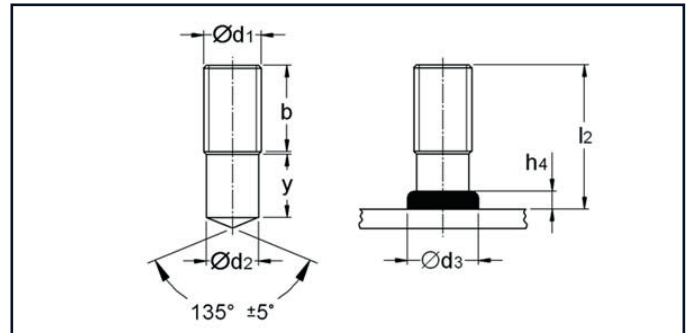
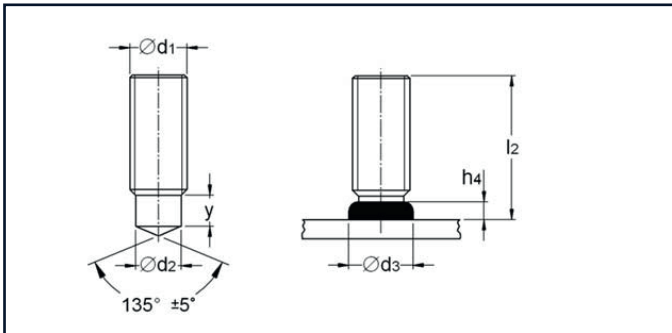

Threaded stud PD, dimensions acc. to EN ISO 13918

Threaded stud RD, dimensions acc. to EN ISO 13918

d ₁	l ₂	h ₄	d ₂	d ₃	y _{min}	b
M 8	15 - 45	3,5	7,19	10	9	
	50 - 60	3,5	7,19	10		40
M 10	20 - 45	4	9,03	12,5	9,5	
	50 - 60					40
M 12	25 - 45	4,5	10,86	15,5	11,5	
	50 - 100					40
M 16	30 - 45	6	14,7	19,5	13,5	
	50 - 100					40
M 20	35 - 50	7	18,38	24,5	15,5	
	55 - 75					40
	80 - 100					80

d ₁	l ₂	h ₄	d ₂	d ₃	y _{min}
M 8	20 - 60	2,5	6,2	9	4
M 10	20 - 60	3	7,9	11,5	5
M 12	25 - 100	4	9,5	13,5	6
M 16	30 - 100	5	13,2	18	11
M 20	40 - 100	6	16,5	23	13

h₄ and d₃ are approximate values which are subject to the welding parameters.

Material: K 800, weldable

Information for material and application:

K 800 has a minimum yield strength of 640 N/mm² and an ultimate tensile strength of abt. 800 N/mm². It can replace screws with grade 8.8 acc. to ISO 898. The fracture elongation A5 is app. 14%.

The low carbon content of app. 0,1% prevents embrittlement after welding as the high strength is achieved by cold forming only. **Therefore, in order to obtain the strength properties, the material must not be subjected to a heat treatment or a coating process in which temperatures above about 100 ° C occur.**

The bend test acc. to EN ISO 14555 puts a higher load to the welding zone compared to standard studs. This needs to be taken into account especially for the type RD. There are higher requirements on the quality of the weld zone compared to steel grade S235 (4.8). As a production test we recommend the tensile test acc. to chapter 11.4 of EN ISO 14555. For the type RD and generally for thick and short studs (ratio diameter / length > app. ¼) the bend test acc. to EN ISO 14555 is not suitable.

The surface needs to be cleaned by grinding before welding. The weld collar should have an uniform shape. The welding parameters current, time, lift, protrusion and plunging speed (damping) need to be kept within narrower limits than usual.

For further information do not hesitate to contact our dept. for application engineering.

K 800 KOCO threaded studs – the new class!

KOCO threaded studs – now in yield strength 640 N/mm²

Advantages compared to the standard property class 4.8:

- Nominal values of tensile strength and yield strength doubled
- No embrittlement during stud welding
- Smaller stud diameters with equal load capacity
- Weight and cost reductions
- Replacement of 8.8 standard screws with KOCO K 800 welding studs possible

Tensile test (example)

	S ₀ [mm ²]	R _{p0,2} [N/mm ²]	F _m [N] R	m [N/mm ²]
Specimen 1 - K 800 (M 20)	245,00	669	188688	771
Specimen 2 - K 800 (M 20)	245,00	666	189723	774
Specimen 3 - S235J2 (M 20)	245,00	486	131070	534
Specimen 4 - S235J2 (M 20)	245,00	477	131071	534

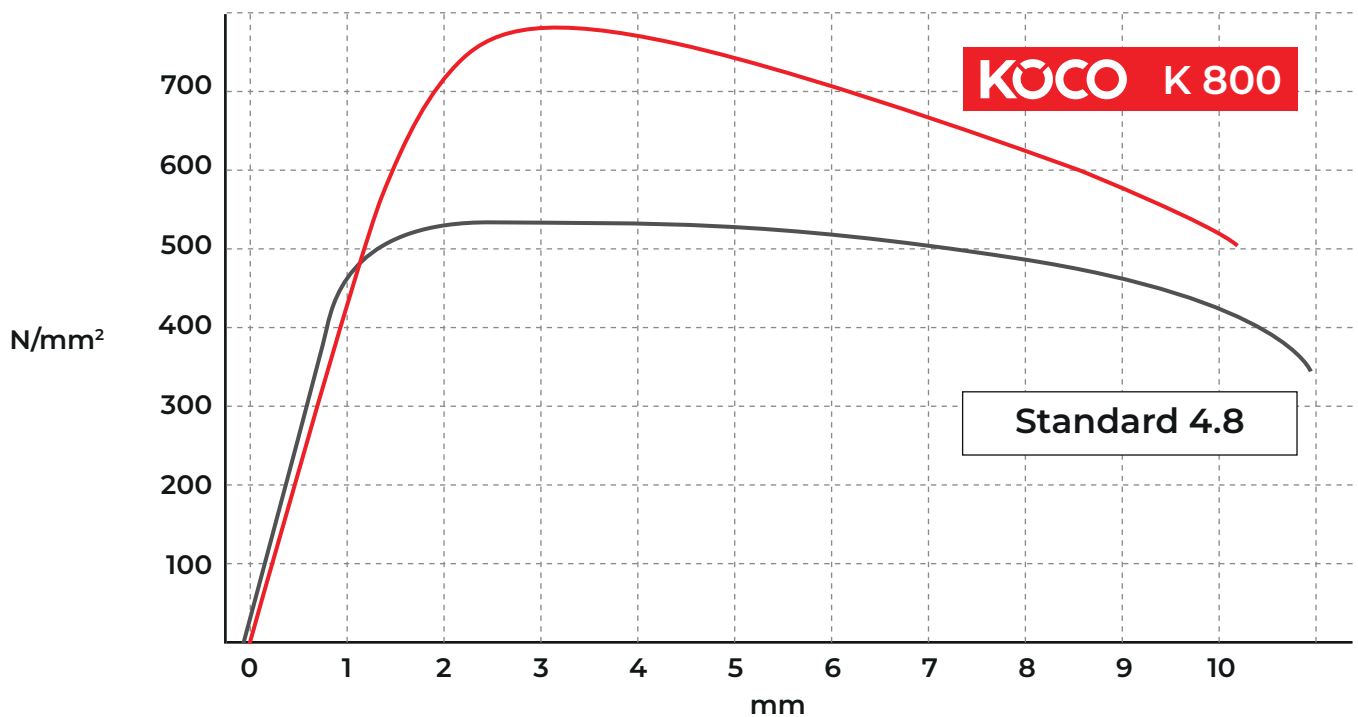

Fracture load Standard 4.8

Fracture load K 800

app.130 kN

app.190 kN